

STANDARD SPECIFICATIONS

ENGINE: MACK, MP7-405M

Peak Horsepower, 405 HP [302 kW] at 1700-1900 RPM
Gov. Horsepower, 370 HP [276 kW] at 2100 RPM
Max. Torque, 1480 lb/ft [2 007 N·m] at 1200 RPM
V-MAC IV — Total Vehicle Electronics
Lube Oil System, 2 Full Flow Filters
Extended Service Interval 15,000 Miles [24 150 km]
or 300 hours
Centri-Max Ultra Plus® Centrifugal Oil Filter
Air Compressor, Meritor WABCO 318 (18.7 CFM)
Starting System Starter, 12-Volt
Batteries, (3) Mack 12-Volt M/F Type, 1980 CCA
Alternator, 12V 100A, Delco (24 SI)
Air Intake System
Air Cleaner, Single Element—Dry Type
Air Restriction Monitor, Grad. Lock Up Type
(Air Cleaner Mtd.)
Exhaust, Single Vertical
Cooling System—Shutterless Type
Aluminum Radiator, 990 sq in Frontal Area
Anti-Freeze to -10°F [-23°C]
Fan Drive, Electronic Modulating
Poly-V Fan Belt w/Auto. Tensioner
Radiator Mounted Bug Screen
Power Leash Engine Brake

CLUTCH: EATON FULLER CL7981

15.5" [394 mm] Ceramic Dampened Disc,
2-Plate, Coaxial Spring, 6 Paddle Disc

TRANSMISSION: MACK, TM308

8-Speed, Ratios: 17.77 Low-0.71 High
PTO Side Gears (RH & LH)
Driveline: Meritor 17N HD Main and Meritor 17N HD
Interaxle w/Coated Splines

CAB: MACK CONVENTIONAL, CA68

Interior Features:

Purebred Interior Trim Level
Color: Sandstone
Ash Tray
Cigar Lighter
Radio Accommodation Package
Coat Hooks
Dispatch Box Mounted on Rear Panel
Overhead Console Including 3 Storage
Compartments w/Retaining Nets
Location for Optional CB
Blend Air HVAC with R134a Refrigerant
4 Dome Lights—2 Driver's Side, 2 Passenger's Side
Infinitely Adjustable Steering Column—
Tilt and Telescope
Steering Wheel, Two Spoke w/Urethane Grip and
Bulldog Horn Cap
Seats:
Driver's, Bostrom Talladega 915, Air Susp.
(Mid-Back)
Rider's Seat (Fixed, Mid-Back)
Seat Belts—Driver and Rider
Lap & Shoulder w/Seat Belt Retractor
Sun Visor—Both Side
Floor Mat, MACK Signature Polyurethane

MACK

GRANITE AXLE BACK

CTP713B



- Cornerstone Chassis
- Axle Back 6 Wheel Truck
- ABS (Anti-Lock Brake System)

STANDARD

ENGINE: MACK MP7-405M
405 HP [302 kW] Peak Horsepower

TRANSMISSION: MACK TM308
8-Speed

FRONT AXLE: MACK FXL12
12,000 lb. [5 443 kg] Capacity

REAR AXLE: MACK SS38R
38,000 lb. [17 237 kg] Capacity
Suspension: SS38 Mack Multileaf
38,000 lb. Rated



STANDARD SPECIFICATIONS

(Continued)

CAB: (continued)

Interior Features: Operational
T.M.C. Recommended Instrument Panel
Driver Information Display
Air Pressure Gauge
Voltmeter
Fuel Level Gauge
Engine Oil Pressure Gauge
Engine Coolant Temperature Gauge
Low Air Pressure Indicator (Light and Buzzer)
Speedometer w/Two-Trip Odometer, Electronic
Tachometer w/Hourmeter, Electronic
High Beam Indicator
Parking Brake On Indicator
Key Type Starting
Engine Shutoff, Key-Type Control
Courtesy Light Switch (Head & Clearance)
Directional Signal

Exterior Features:
Welded Steel Shell, Galvanized
MACK Rust Preventative Procedures
Vents (Screened)
Fresh Air Inlet for Heater
Cab Steps—Two Step Aluminum w/Self-Cleaning Treads
Safety Glass Windows
Tinted 2-Piece Windshields, Side & Rear Glass
Windshield Wipers—Two, Fixed Arm & Blade Type
Wiper Motor (Electric), (1), Two Speed Intermittent
Windshield Washers, Electric, Wiper Mtd. with
5 qt. [4.7 L] Translucent Reservoir
Mirrors, West Coast Bulldog Bright Finish, Includes
8" Convex RH & LH w/Stainless Steel Swing
Away Arms
Headlamps—Halogen, Flush Mounted with Replaceable Bulb
Daytime Running Lights
Identification and Clearance Lamps (5)
Side Markers—Lamps and Reflectors
Front Turn Signals
Transistorized Flasher
Horns, Air, MACK Rectangular Single Trumpet &
Electric, (Single Tone)
Doors—Galvanized Steel with:
Visibility Door with Roll-Up Tinted Windows
Grab Handles (Stainless Steel), RH & LH Behind Door
Cab Mounting: Trunnion Front, Dual Air Suspended Rear

HOOD & FENDERS:

One Piece Fiberglass with Splash Aprons Tilts Forward
Grille—Argent Silver Metal

FRAME:

WB—Wheelbase—192"
LP—Load Platform—201"
CA—Cab to Axle—127"
AF—C/L Axles to End of Frame—74"
Frame Rails—Steel with 120,000 psi Minimum Yield
Cross Section—11.81" x 3.54" x .32" [300 x 90 x 8 mm]
without Channel Reinforcement
Section Modulus—17.7 in.³
RBM (per rail)—2,120,000 lb. in.
Crossmembers—Back of Cab to Rear Axle: Heavy Duty Back-
To-Back Channels
Behind Rear Axle: Single Channel Type
Extended Swept Back Steel Bumper
BBC—Bumper to Back of Cab—122"
Tow Hooks

FUEL TANKS:

Steel 22" Diameter
Capacity/Location, 50 gal LH

FRONT AXLE: MACK, FXL12

12,000 lb Capacity w/Unitized Front Hub and
Synthetic Lubricant
Meritor Brakes, "S" Cam 16.5" x 5", w/o Dust Shields
Slack Adjusters—Automatic
Suspension, MACK Taperleaf Spring with 12,000 lb
[5 443 kg]
Ground Load Rating
Shock Absorbers, Suspension Tuned
Integral Power Steering
Wheel Equipment, 22.5" x 8.25" Hub Piloted Accuride
Steel Disc Wheels Outboard with Cast Drums and
Ferrous Hubs
Tires: 11R22.5 (singles)

REAR AXLE: MACK, SS38R

38,000 lb [17 237 kg] Capacity Axle
Carrier—Malleable—CRDPC92/CRD93
Suspension—SS38R Mack Anti-Sway Multileaf 38,000 lb
[17 237 kg] Capacity
Brakes—"S" Cam 16.5" x 7" [419 x 178 mm]
Meritor "Q-Plus" Brakes w/o Dust Shields
Slack Adjusters—Automatic
Aux. Spring Brake Chambers, Tamper
Resistant 30/30 Double Diaphragm Type,
Mechanical Spring Release, 4 Units, 2 Mtd. Each Axle
Wheel Equipment, 22.5" x 8.25" Accuride 10 Hole, 11.25"
Bolt Circle, Hub Piloted Steel Disc Wheels with
Outboard Cast Drums and Ferrous Hubs
Tires: 11R22.5 14 (duals)

AIR/BRAKE:

ABS (Anti-Lock Brake System)
Dual Air Brake System
Air Dryer—Heated
Air Reservoirs—Air Capacity of 9,573 in.³

ELECTRICAL:

Black Molded Battery Box Cover
Engine Protection Shutdown System
Flasher, Transistorized
Chassis Electrical
Negative Ground
12-Volt Electrical Circuits and Bulbs
Fuse/Breaker Protected Circuits
Breaker Protected Headlamp & Windshield Wiper Circuits
Rear Lighting, (2) Combination Stop, Tail Directional &
Back-up Lights

PAINT:

Cab, Hood and Fenders
Color: MACK White, High Gloss
Chassis Running Gear
Color: MACK Black (Urethane)

CHASSIS SPECIFICATIONS

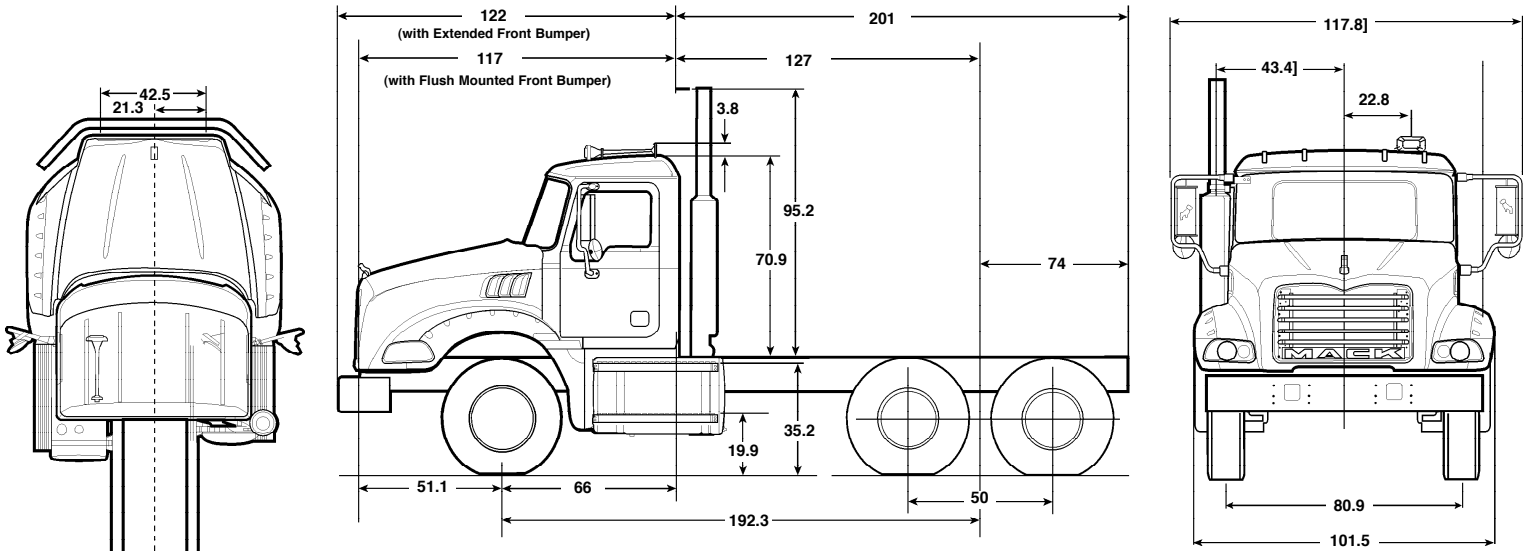

AVAILABLE DRIVELINE COMPONENTS

ENGINES	
MODEL	*HORSEPOWER
MACK	
MP7-365C	365 HP [272 kW] @ 1500-1700 340 HP [254 kW] @ 1950
MP7-395C	395 HP [295 kW] @ 1500-1700 370 HP [276 kW] @ 1950
MP7-365M	365 HP [272 kW] @ 1500-1900 335 HP [250 kW] @ 2100
MP7-405M	405 HP [302 kW] @ 1500-1900 370HP [276 kW] @ 2100

TRANSMISSIONS		
MODEL	SPEEDS	RATIOS (LOW/HIGH)
MACK		
TM308	8	17.77/0.71
TM308M	8	17.77/0.71
TM309	9	25.21/0.71
TM309M	9	25.21/0.71
T309	9	11.40/0.71
T309(L)	9	13.93/0.71
T309(LR)	9	13.93/0.71
T310	10	13.81/0.73
T310M	10	17.35/0.73
T310ME	10	17.35/0.73
T310MLR	10	27.31/0.71
T313 LR	13	16.42/0.71
T313 L	13	16.42/0.71
T318LR	18	16.42/0.71
T318L	18	16.42/0.71
ALLISON		
4500 RDS	5	4.70/0.76
4500 RDS	6	4.70/0.67
4000 RDS	5	3.51/0.74
4000 RDS	6	3.51/0.64
4500 RDS R	5	4.70/0.76
4500 RDS R	6	4.70/0.67
4000 RDS R	5	3.51/0.74
4000 RDS R	6	3.51/0.64
EATON FULLER		
RTX-13609B	9	12.57/0.73
RTX-14609B	9	12.56/0.73
RTX-16709B	9	12.57/0.73
RTO-14908LL	10	14.56/0.74
RTO-16908LL	10	14.56/0.74
FRO-16210C	10	12.69/0.74
RTO-14909ALL	11	26.08/0.73
RTO-16909ALL	11	26.08/0.73

AXLES		
CAPACITY	MAKE	MODEL
FRONT AXLES		
12,000 lb. [5 443 kg]	MACK	FXL12
14,600 lb. [6 486 kg]	MACK	FXL14.6
18,000 lb. [8 165 kg]	MACK	FXL18
20,000 lb. [9 072 kg]	MACK	FXL20
23,000 lb. [9 072 kg]	MACK	FXL23
TANDEM REAR AXLES		
38,000 lb. [17 239 kg]	MACK	S38R/SB38R
40,000 lb. [18 144 kg]	MACK	SB38R
	DANA SPICER	DS405P
44,000 lb. [19 958 kg]	MERITOR	RT40-145
	MACK	S440
46,000 lb. [20 866 kg]	MACK	S462/S440
	DANA SPICER	DS463P
52,000 lb. [23 636 kg]	MERITOR	RT46-160
	MACK	S52
58,000 lb. [26 309 kg]	MACK	S582
65,000 lb. [29 484 kg]	MACK	S652

OPTIONAL EQUIPMENT

FRAME:

Optional Frame without Reinforcement

11.81" x 3.54" x 0.32" [300 x 90 x 8 mm] without inside channel reinforcement
Section Modulus: 17.7 in.³
Resisting Bending Moment, RBM: 2,120,000 lbs. in. [239 500 N•m]

11.81" x 3.54" x 0.37" [300 x 90 x 9.5 mm] without inside channel reinforcement
Section Modulus: 20.6 in.³
Resisting Bending Moment, RBM: 2,470,000 lbs. in. [279 060 N•m]

11.81" x 3.54" x 0.437" [300 x 90 x 11.1 mm] without inside channel reinforcement
Section Modulus: 23.5 in.³
Resisting Bending Moment, RBM: 2,820,000 lbs. in. [318 600 N•m]

11.81" x 4.13" x 0.437" [300 x 105 x 11.1 mm] without inside channel reinforcement
Section Modulus: 26.3 in.³
Resisting Bending Moment, RBM: 3,160,000 lbs. in. [357 020 N•m]

Wheelbase Availability

163" [4 140 mm] to 300" [7 620 mm]

Optional Frame w/Optional Reinforcement

11.81" x 3.54" x 0.32" [300 x 90 x 8 mm] with
11.10" x 2.93" x 0.20" [282 x 74 x 5 mm] partial inside channel reinforcement
Section Modulus: 26.9 in.³
Resisting Bending Moment, RBM: 3,230,000 lbs. in. [364 900 N•m]

11.81" x 3.54" x 0.37" [300 x 90 x 9.5 mm] with partial inside channel reinforcement
Section Modulus: 29.8 in.³
Resisting Bending Moment, RBM: 3,580,000 lbs. in. [404 470 N•m]

11.81" x 3.54" x 0.37" [300 x 90 x 9.5 mm] with full inside channel reinforcement
Section Modulus: 29.8 in.³
Resisting Bending Moment, RBM: 3,580,000 lbs. in. [404 470 N•m]

11.81" x 3.54" x 0.437" [300 x 90 x 11.1 mm] with inside channel reinforcement
Section Modulus: 32.7 in.³
Resisting Bending Moment, RBM: 3,920,000 lbs. in. [442 900 N•m]

11.81" x 4.13" x 0.437" [300 x 105 x 11.1 mm] with inside channel reinforcement
Section Modulus: 35.5 in.³
Resisting Bending Moment, RBM: 4,260,000 lbs. in. [481 290 N•m]

CAB, INTERIOR TRIM LEVELS:

“**Purebred**”: For complete description, refer to MackTraQ

“**Pedigree**”: For complete description, refer to MackTraQ

“**Champion**”: For complete description, refer to MackTraQ

OTHER OPTIONAL EQUIPMENT:

Air Dryers
Alcohol Evaporation
Aluminum Bumpers
Back-up Alarm
Bright Finish Equipment:
Hood Air Intake Louvers
Battery Box Covers
Bumpers
Fuel Tank Steps & Straps
Polished Aluminum Air Reservoirs
Radiator Guard
Bumper, Stylized with Stone Guard
Bumper, Swept Back w/Center Tow Pin
Clearance Lights, Bullet Style
Co-Pilot Driver Information Display
Crossmembers, I-Beam Type
Engine Cold Starting Aids
Engine Heaters
Exhaust, Dual
Exterior LED Lighting
Floor Mat Wear Area Inserts
Gauge Cluster Options:
Air Application
Air Restriction, Dash Mounted
Axle Oil Temperature
Engine Oil Temperature
Exhaust Pyrometer
Fuel Pressure
Manifold Pressure
Transmission Oil Temperature

Hand Control Valve, with Spring Return
Hubodometer
Inside—Outside Air Intake
Interwheel Power Divider
Instrument Panel Trim—Brushed Nickel,
Wood Appearance
Mirror Options, (Stylized)
Mud Flaps
Paint—Special Paint Designs
Perimeter Worksite Lighting
Pintle Hook—20 Ton Crossmember
Power Take-Off Options:
REPTO
Front End PTO (Crankshaft Adapter)
Power Windows and Door Locks
Pusher/Tag Axle Mtg. Clearance
Radiator Guard
Radio Options, Stereo/Cassette/CD
Seat Options, Driver & Rider
Seat—Two Person Rider
Semi or Full Trailer Connections Package
Sliding Rear Window
Steering Wheel, MACK Special Edition,
Hardwood Chrome
Sun Visor, Exterior
Synthetic Lubricants
Tandem Axle Spacing Options
Trailer Access Package
Trailer Hook-up Lamp
Waterproof Electrical Connections

Wheel Equipment:
Steel or Aluminum Disc on Front
Cast Spoke, Steel or Aluminum
Disc on Rear

OTHER COMPONENT OPTIONS
MAY BE AVAILABLE UPON REQUEST



The information in this brochure was accurate as known as of the date of the publication. Illustrations may not be representative of current product. Mack Trucks, Inc. reserves the right to make changes in specifications, equipment or design, or to discontinue models or options without notice at any time.